

### All School's Specific Notes

02 41 19 002	Dashed lines indicated extent of demoed work
08 11 13 002	Install new 36" HM Door and Frame with new hardware
08 11 13 003	Remove Door jams and finish masonry edge; ensure MIN 32" wide opening; paint to match CMU
09 30 13 005	Install new wall tile flush and straight, floor to ceiling at this plumbing wall only
10 21 13.19 001	Install new toilet partitions (typical)
10 28 13 001	Install wall hung mirror here; center over fixture unless noted otherwise
10 28 13 002	Install hand dryer here; coordinate with electrical & mechanical
22 42 00 001	Coordinate new fixture installations with mechanical, typical for new
22 42 00 002	New fixtures only in this toilet room; coordinate with mechanical
22 42 00 003	New touchless faucet at sink/cabinet; coordinate with mechanical
22 47 13 001	Install double drinking fountain here; coordinate with mechanical & electrical drawings
22 47 13 002	Install single drinking fountain here with bottle filler attachment; coordinate with mechanical & electrical drawings

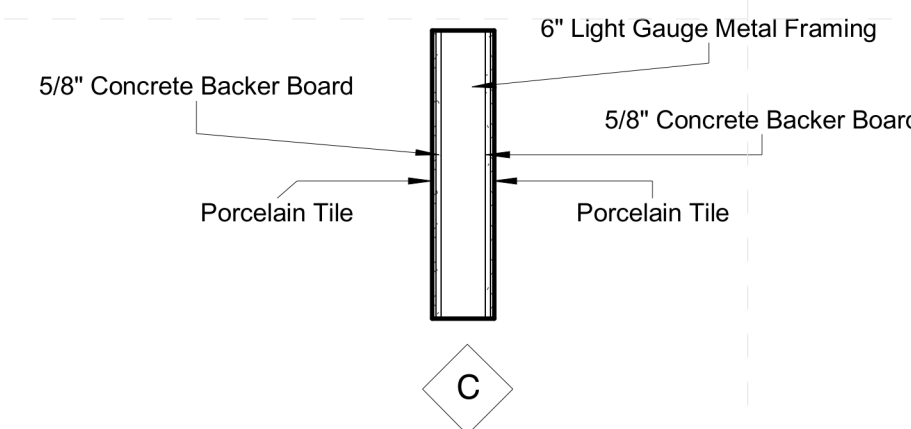

Wall Standards  
1/2" = 1'-0"

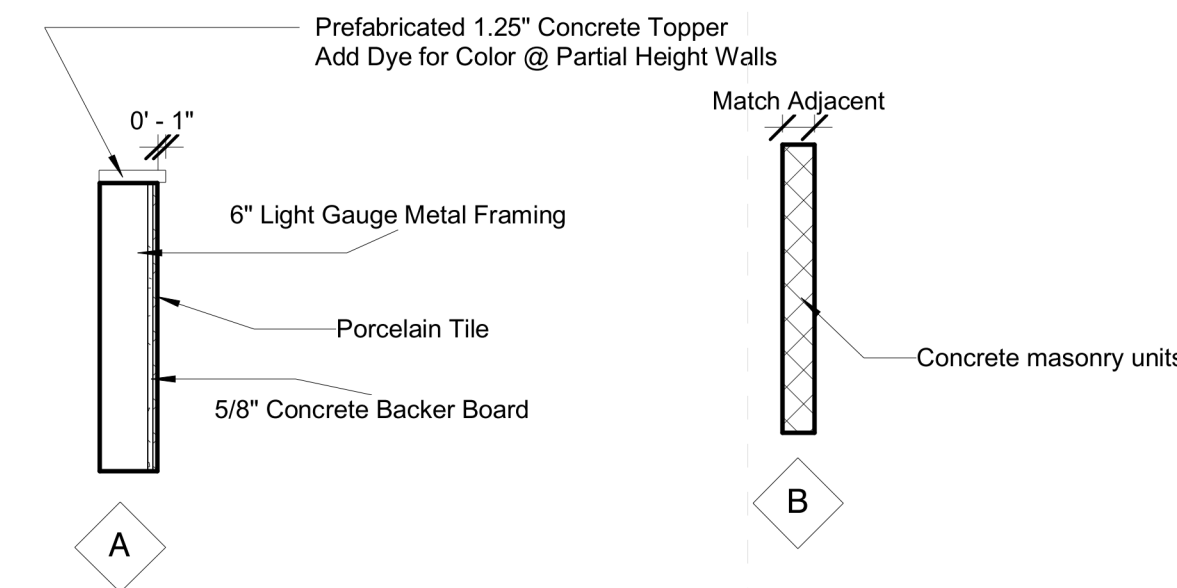
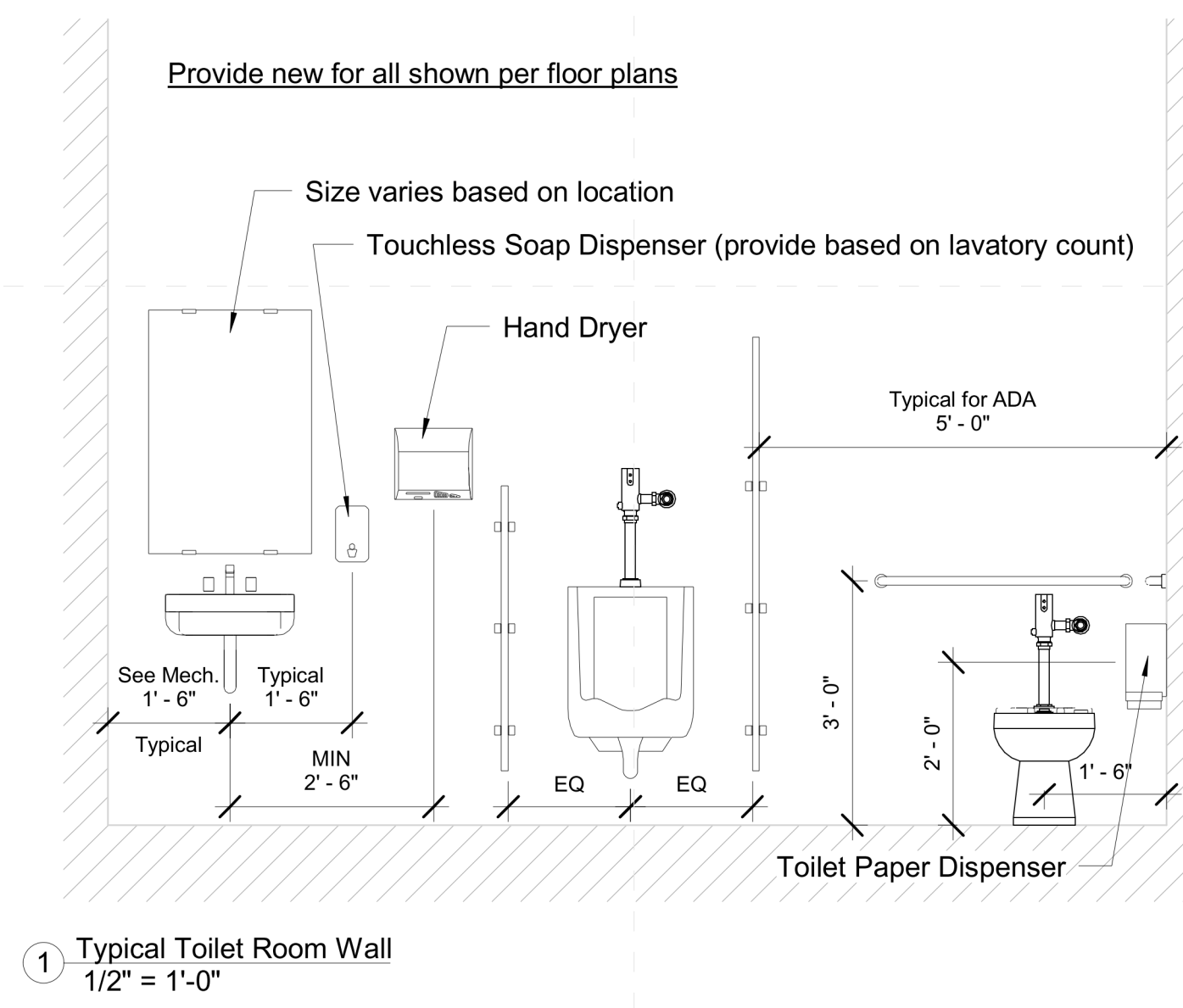

Front of School



Toilets South



Toilets South



Toilets Central



Toilets Central



Toilets North



Toilets North

Architects

One Jackson Place- 250  
188 East Capitol Street  
Jackson, MS 39201  
p 601.352.5411

201 Park Court Suite B  
Ridgeland, MS 39157  
p 601.790.9432

161 Lameuse St. Suite 201  
Biloxi, MS 39530  
p 228.374.1409

dalebaileyplans.com

Not For  
Construction

Sunflower Consolidated School District ESSER 2&3 Phase I  
Lockard Elementary School: 302 College Ave., Indianola, MS 38751

Construction  
Documents

Project No	21027
Date	Issue Date
Revisions	Rev Date



General RCP Demolition Notes

- Where ceiling transitions from new ceiling to existing ceiling, coordinate with Architect detail.
- Remove all existing ceiling grid & tile unless noted otherwise, as well as any wall fasteners and/or mastics attached therein where shown to be replaced by new materials.
- Owner has right of refusal for all demo work. If not retained, GC to be responsible for disposal.
- Verify all existing conditions. Notify architect of any discrepancies between the existing conditions and these documents. The Contractor is to consider the additional work required by any discrepancies to be included in this Contract.
- Burying or Burning of materials will not be permitted on site.
- Repair any damage caused to building construction identified to remain.
- Refer to other discipline drawings for additional demolition information as noted.
- Existing loose school property to be the responsibility of the school district, removal of property by owner to be coordinated between the contractor and school district.
- Where areas are removed or altered, patch, repair, & paint to match adjacent surface material and finish.
- No work in rooms with ceiling open to the structure above, unless noted otherwise.

Ceiling Legend

- Moisture Resistant Acoustical Lay In Ceiling
- Colored Acoustical Lay In Ceiling
- Vinyl Faced Acoustical Lay In Ceiling
- Gypsum Board Ceiling
- 2x2 Acoustical Lay In Ceiling
- Plaster/Stucco
- Concealed Fastener Painted Metal Soffit
- 2x2 Fluorescent Fixture
- Surface-Mounted Fluorescent Light Fixture
- Recessed Can Light Fixture
- HVAC Supply Grille
- HVAC Return Grille
- Exterior Wall Light
- Interior Wall Light
- Open to Structure (OTS)



1 RCP - Demolition  
1/16" = 1'-0"

Not For  
Construction

Sunflower Consolidated School District ESSER 2&3 Phase I  
Lockard Elementary School: 302 College Ave., Indianola, MS 38751

Construction  
Documents

Project No	21027
Date	Issue Date
Revisions	Rev Date

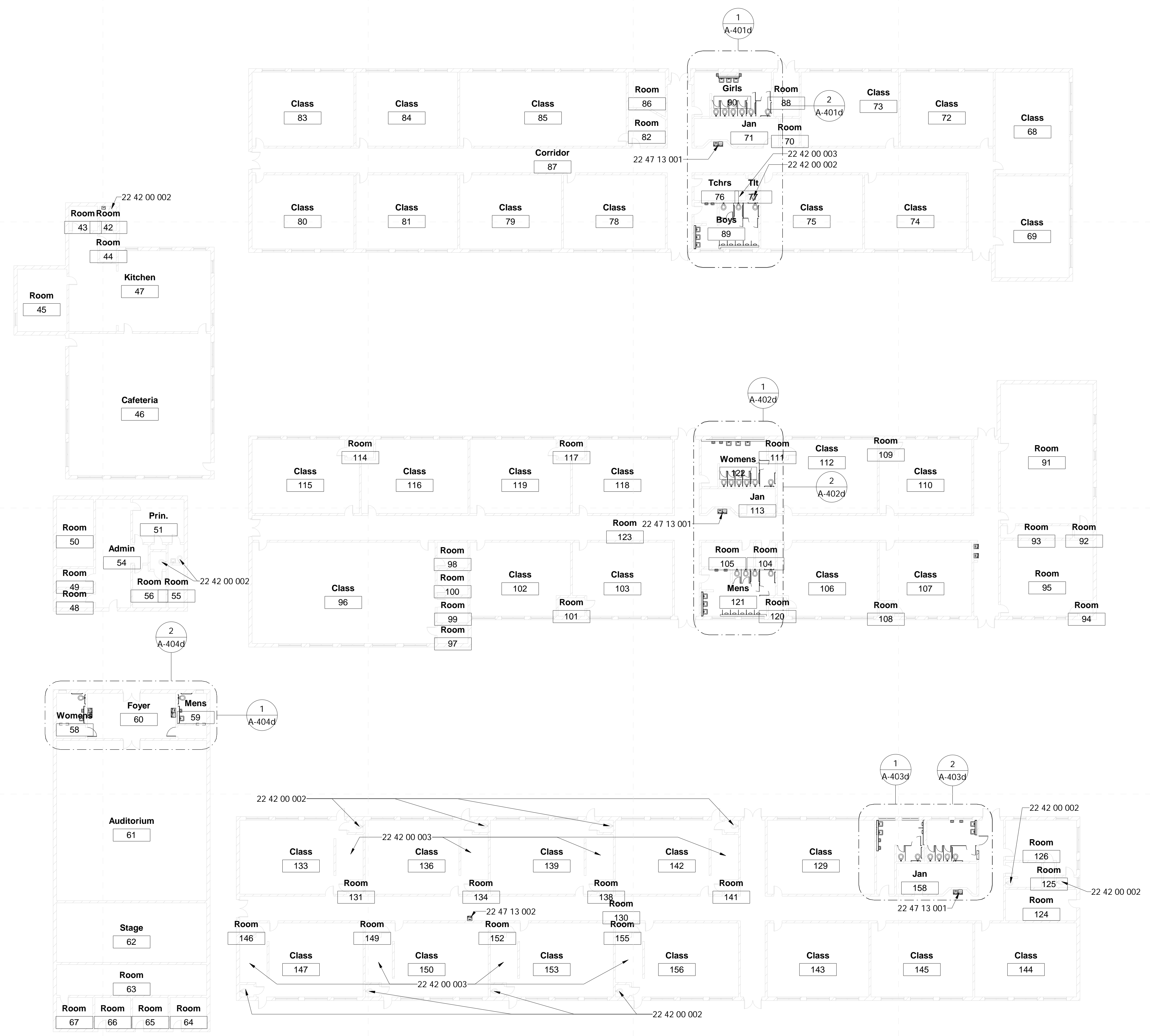

Specific Notes

- 22 42 00 002 New fixtures only in this toilet room: coordinate with mechanical
- 22 42 00 003 New touchless faucet at sink/cabinet: coordinate with mechanical
- 22 47 13 001 Install double drinking fountain here: coordinate with mechanical & electrical drawings
- 22 47 13 002 Install single drinking fountain here with bottle filler attachment; coordinate with mechanical & electrical drawings

1 Main Floor - New Construction  
1/16" = 1'-0"

General RCP Notes

- All ceiling heights shall be same as existing or lower, unless noted otherwise.
- Contractor shall paint all surfaces above 8'-8" at wall, roof, and ceiling, as well as anything attached therein at all exposed sections of ceilings where not covered by new 2x2 ACT, unless noted otherwise.
- Repair/replace any and all ceiling damaged due to construction activities.
- Bent ceiling grid damaged due to construction activities shall be replaced or bent to appear as new in shape.

Ceiling Legend

- Moisture Resistant Acoustical Lay In Ceiling
- Colored Acoustical Lay In Ceiling
- Vinyl Faced Acoustical Lay In Ceiling
- Gypsum Board Ceiling
- 2x2 Acoustical Lay In Ceiling
- Plaster/Stucco
- Concealed Fastender Painted Metal Soffit
- 2x2 Fluorescent Fixture
- Surface-Mounted Fluorescent Light Fixture
- Recessed Can Light Fixture
- HVAC Supply Grille
- HVAC Return Grille
- Exterior Wall Light
- Interior Wall Light
- Open to Structure (OTS)

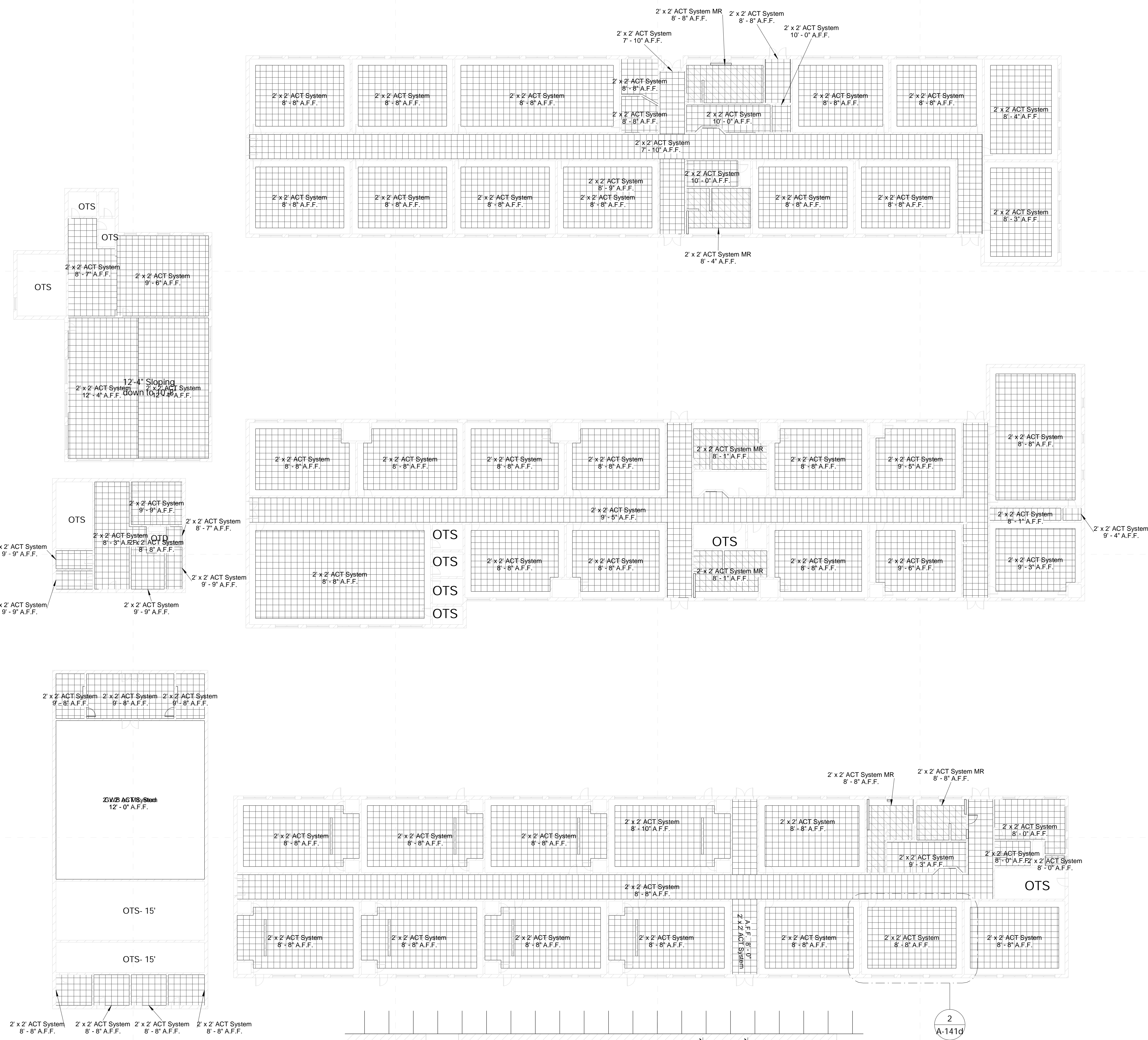

1 RCP - New Construction  
1/16" = 1'-0"

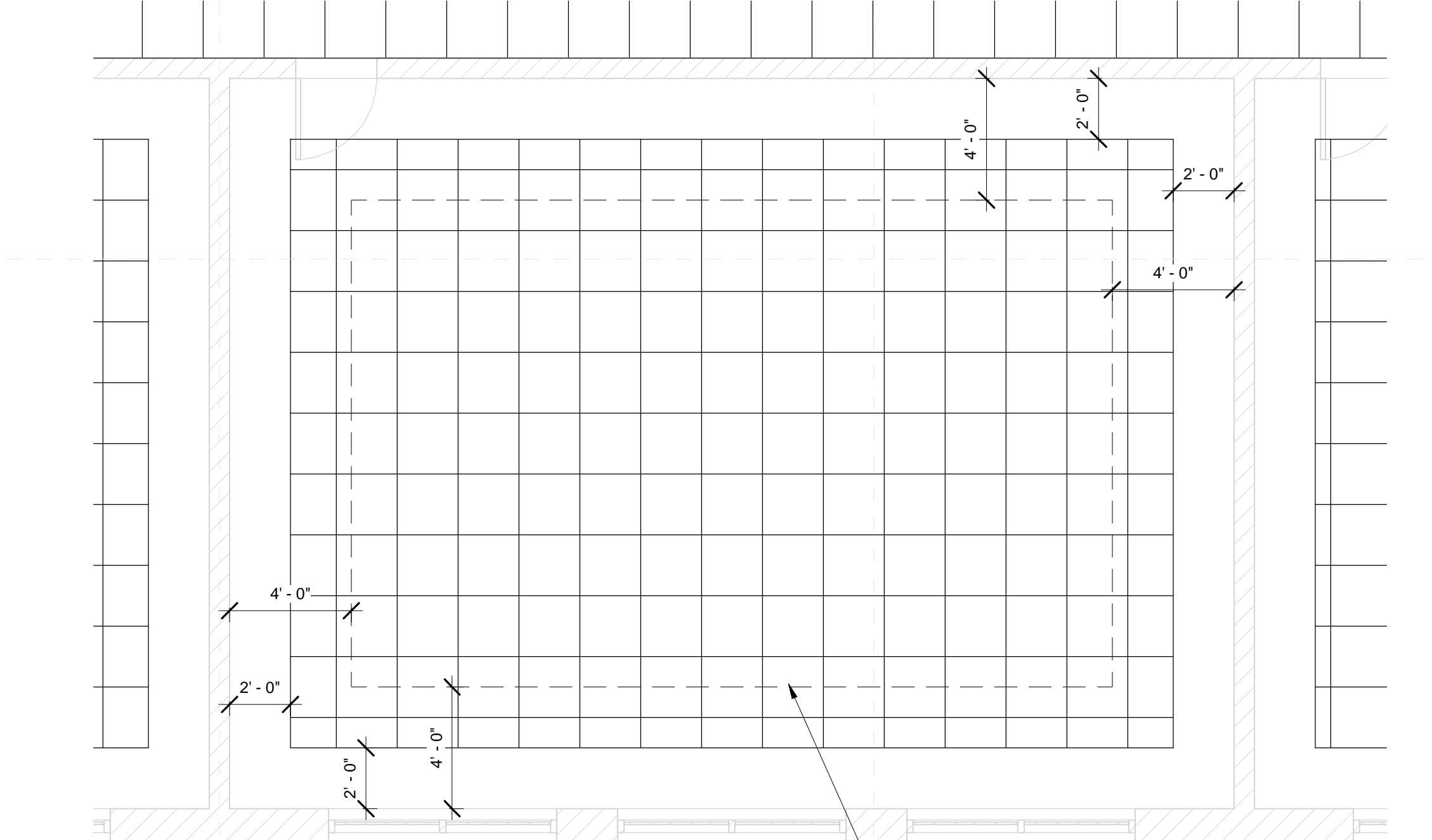

2 Typical Ceiling Layout  
1/4" = 1'-0"

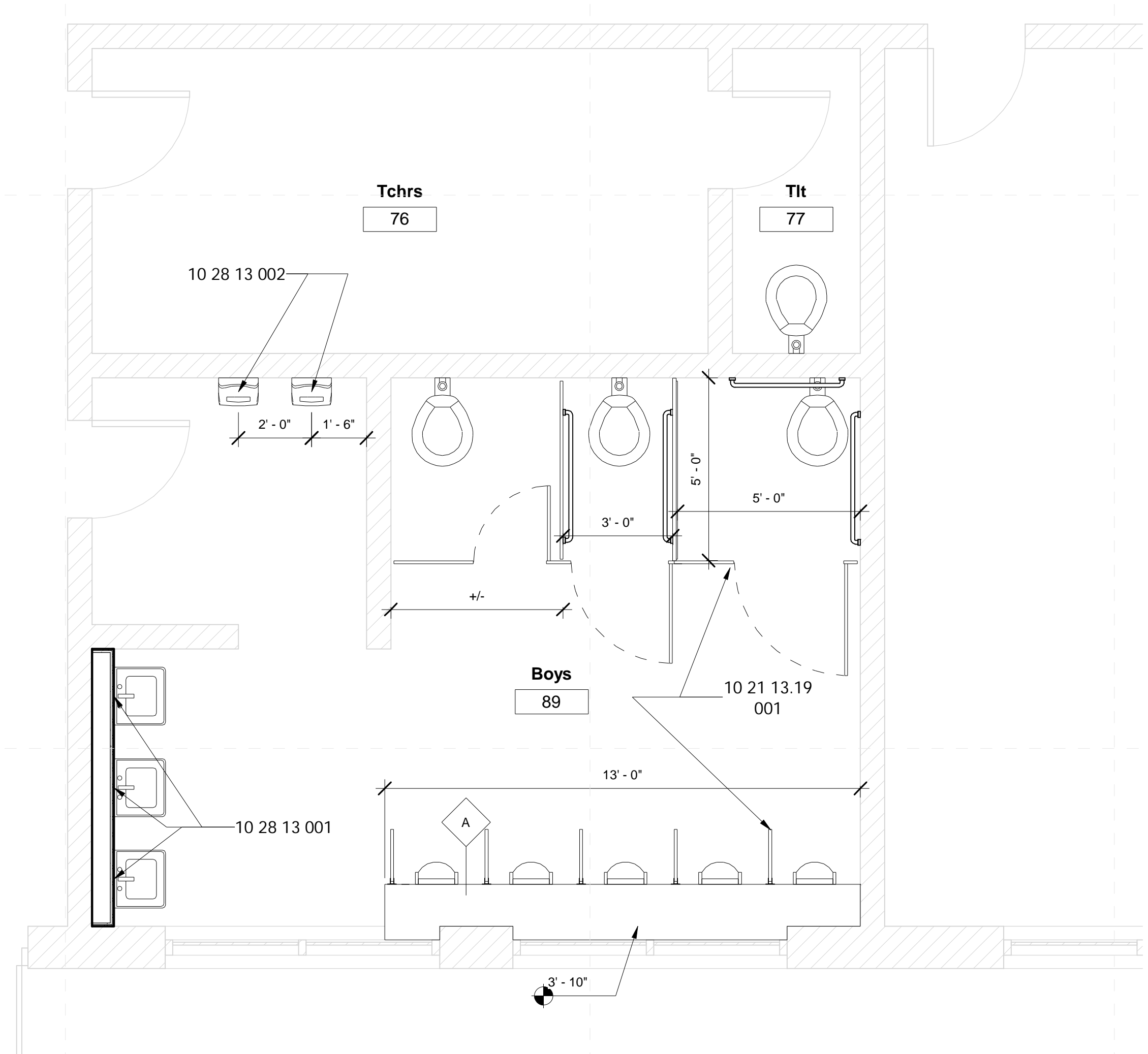
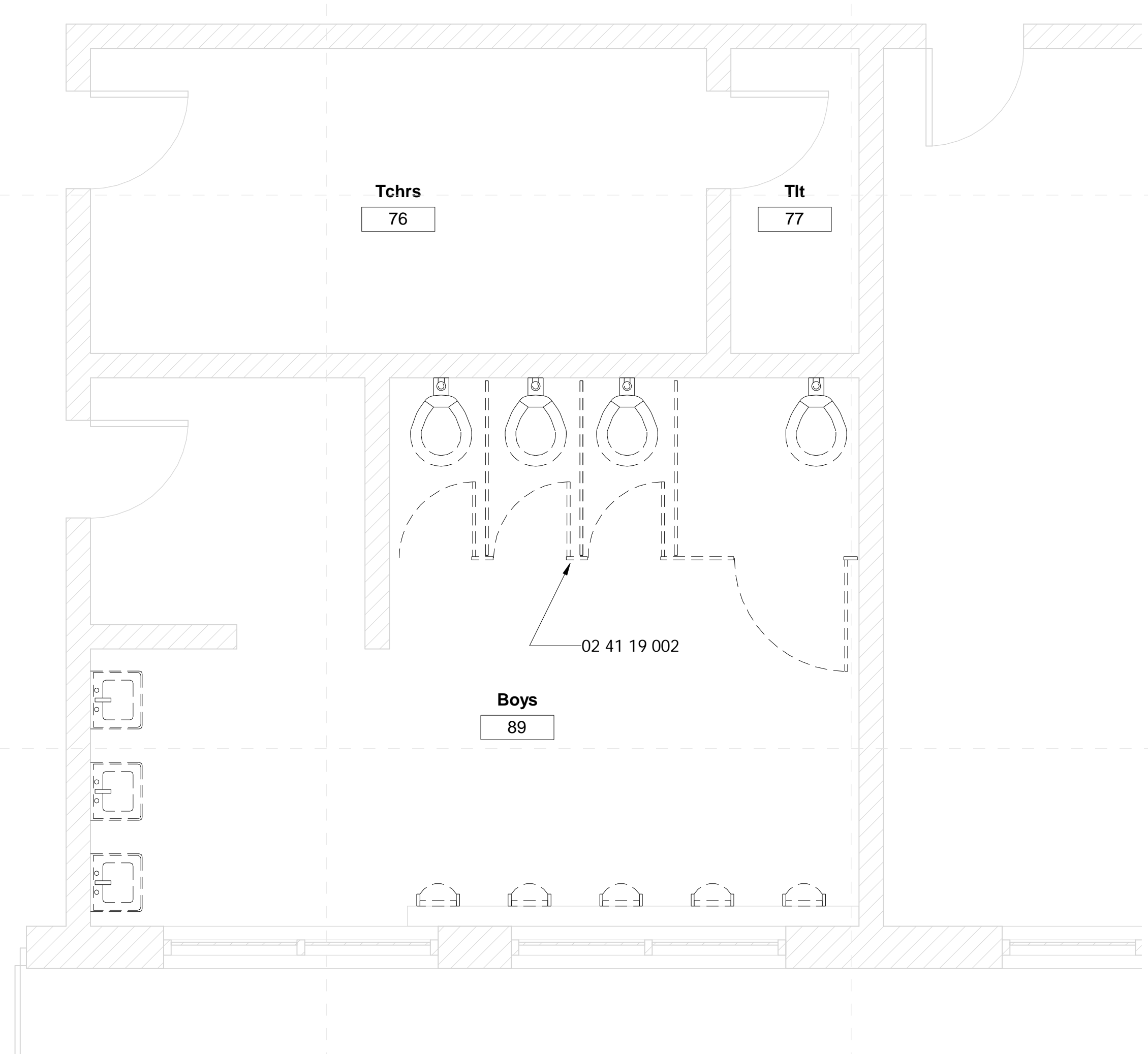
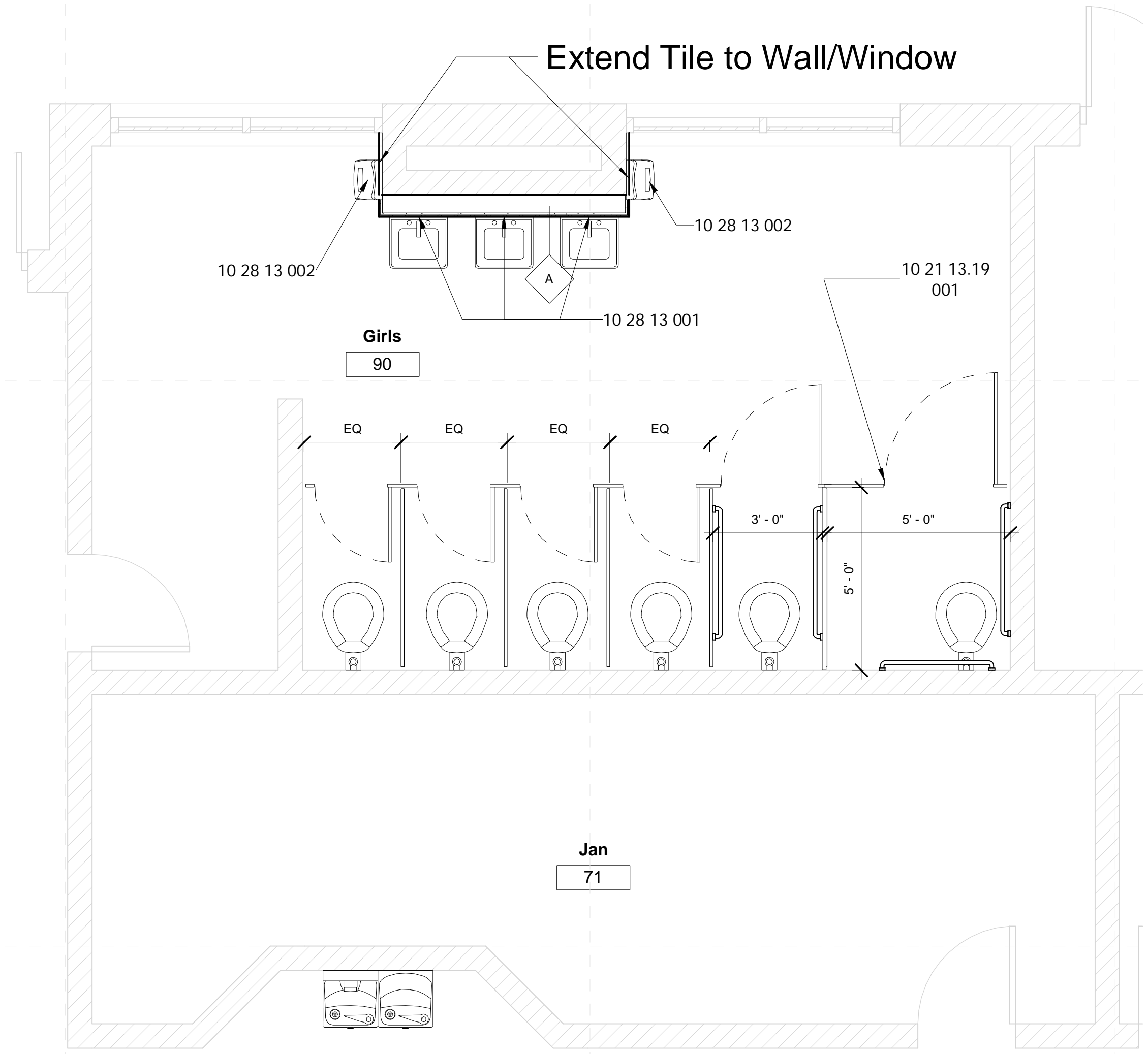
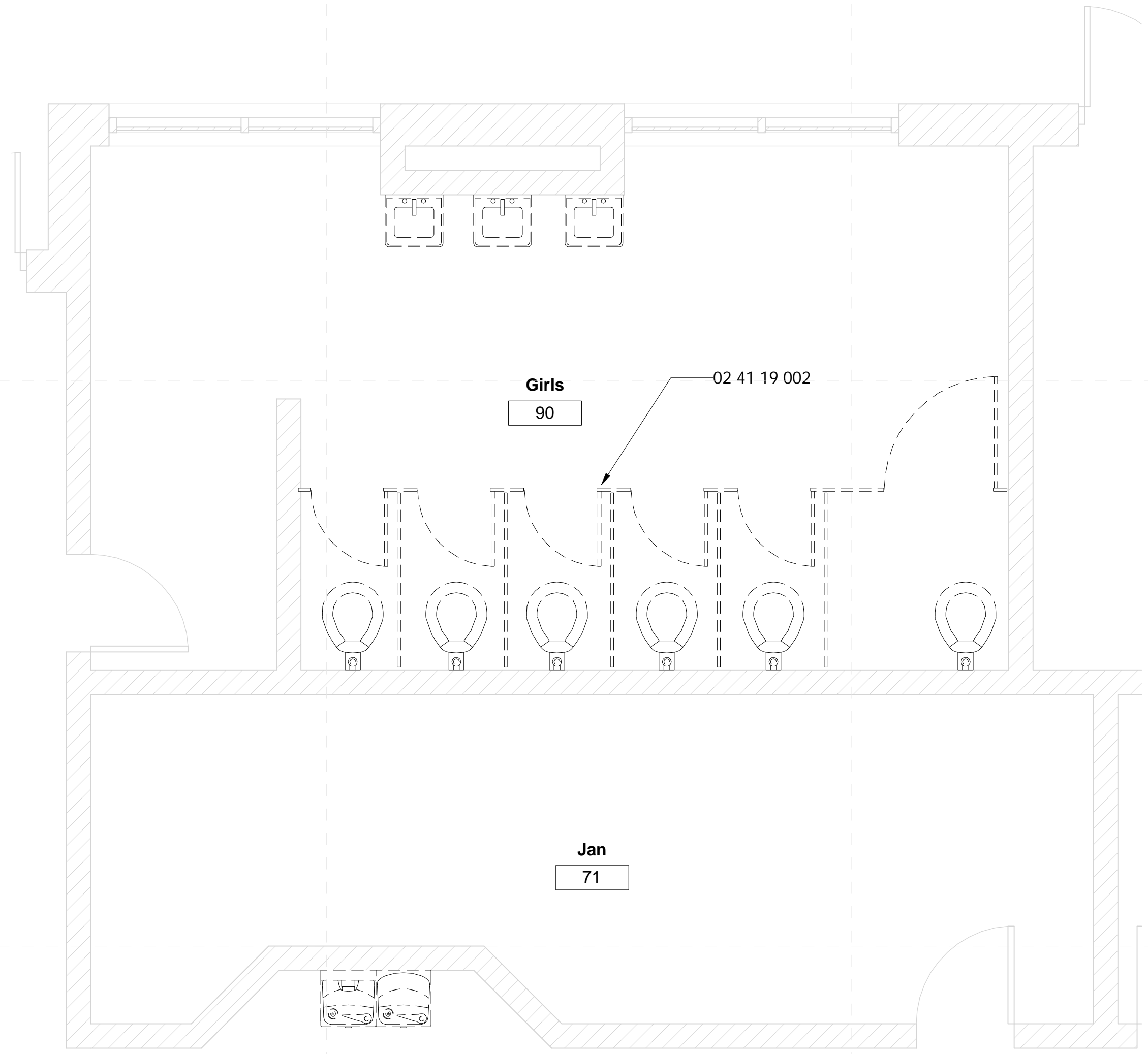

1 Toilets (North) - Demolition  
3/8" = 1'-0"

2 Toilets (North) - New Construction  
3/8" = 1'-0"

General Demolition Notes

- Where floor transitions from new floor to existing floor, a floor transition strip is to be provided. A knock-down frame is to be provided in place of the existing frame where the opening is a part of corridor.
- Remove all existing flooring, ceiling tile, rubber base, etc., where shown to be replaced by new materials in the finish schedule. RE: Floors plans, RCP, and Finish Schedule
- Owner has right of refusal for all demo work. If not retained, GC to be responsible for disposal.
- Verify all existing conditions. Notify architect of any discrepancies between the existing conditions and these documents. The Contractor is to consider the additional work required by any discrepancies to be included in this Contract.
- Burying or Burning of materials will not be permitted on site.
- Repair any damage caused to building construction identified to remain.
- Refer to other discipline drawings for additional demolition information as noted
- Schedule with the Owner any demolition that involves exposing to the weather the interior portions of building to remain. This work is to be performed during good, dry weather or temporary waterproof barrier walls shall be constructed at all occurrences where the demolition exposes weather to the interior of portions of buildings to remain.
- Existing loose school property to be the responsibility of the school district, removal of property by owner to be coordinated between the contractor and school district.
- Where areas are removed or altered, patch, repair, & paint to match adjacent surface material and finish.

Specific Notes

02 41 19 002	Dashed lines indicated extent of demoed work
10 21 13.19 001	Install new toilet partitions (typical)
10 28 13 001	Install wall hung mirror here: center over fixture unless noted otherwise
10 28 13 002	Install hand dryer here: coordinate with electrical & mechanical

General Finish Plan Notes

- All flooring transitions are to occur at center line of door panel.
- Patch tile at all floors and walls with matching material where missing or removed due to construction, unless noted otherwise.
- New Fixture locations shall be coordinated with mechanical sheets.
- Install new grab bars at all ADA & AMB toilets
- Paint all exposed CMU at renovated toilets.
- Paint all tile wainscot.
- Clean floor grout and reseat.

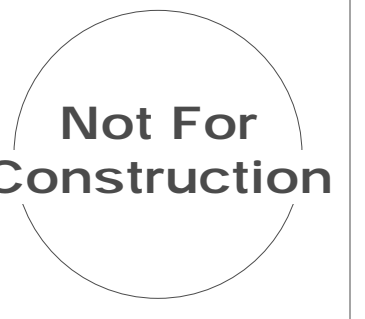

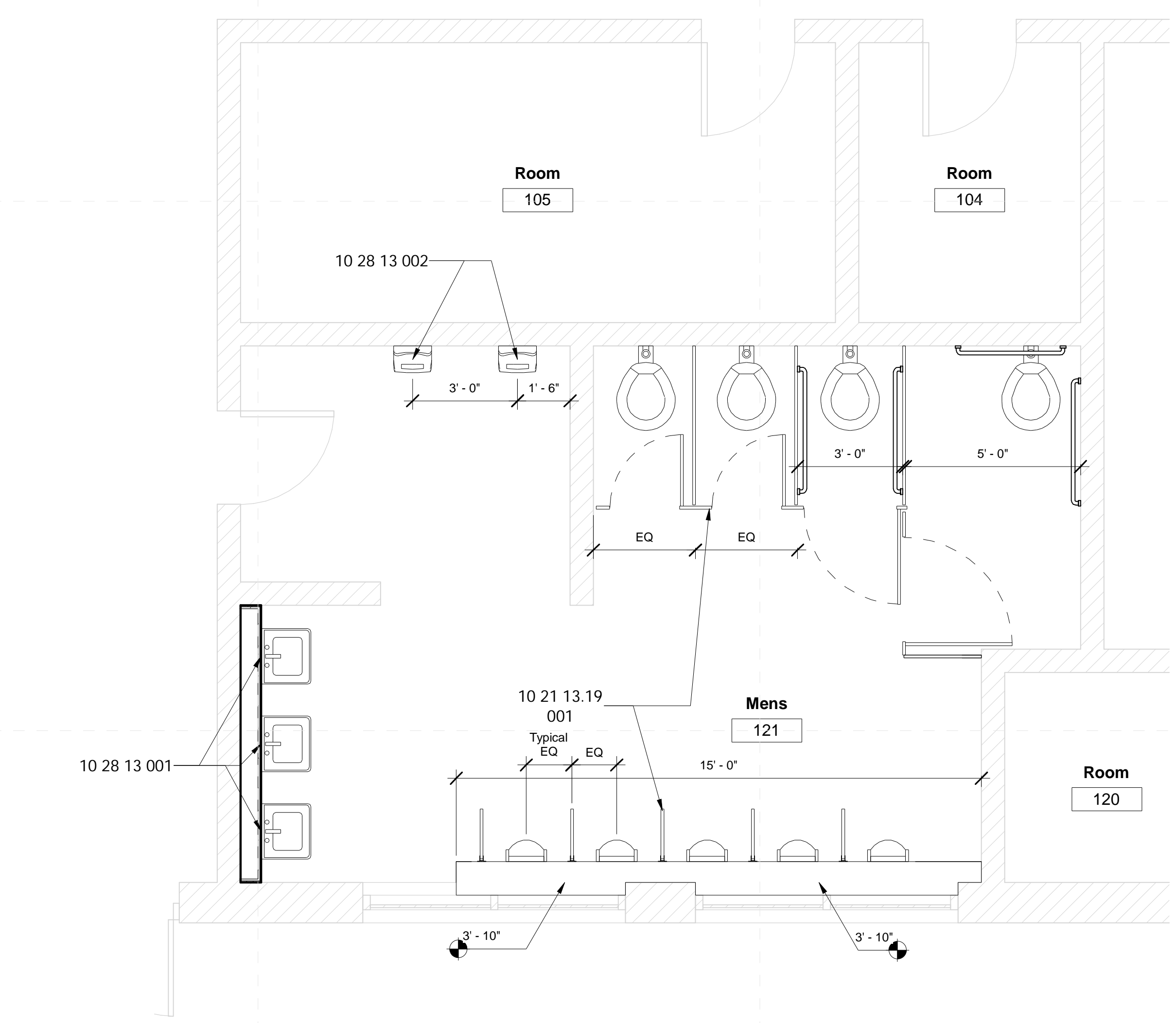
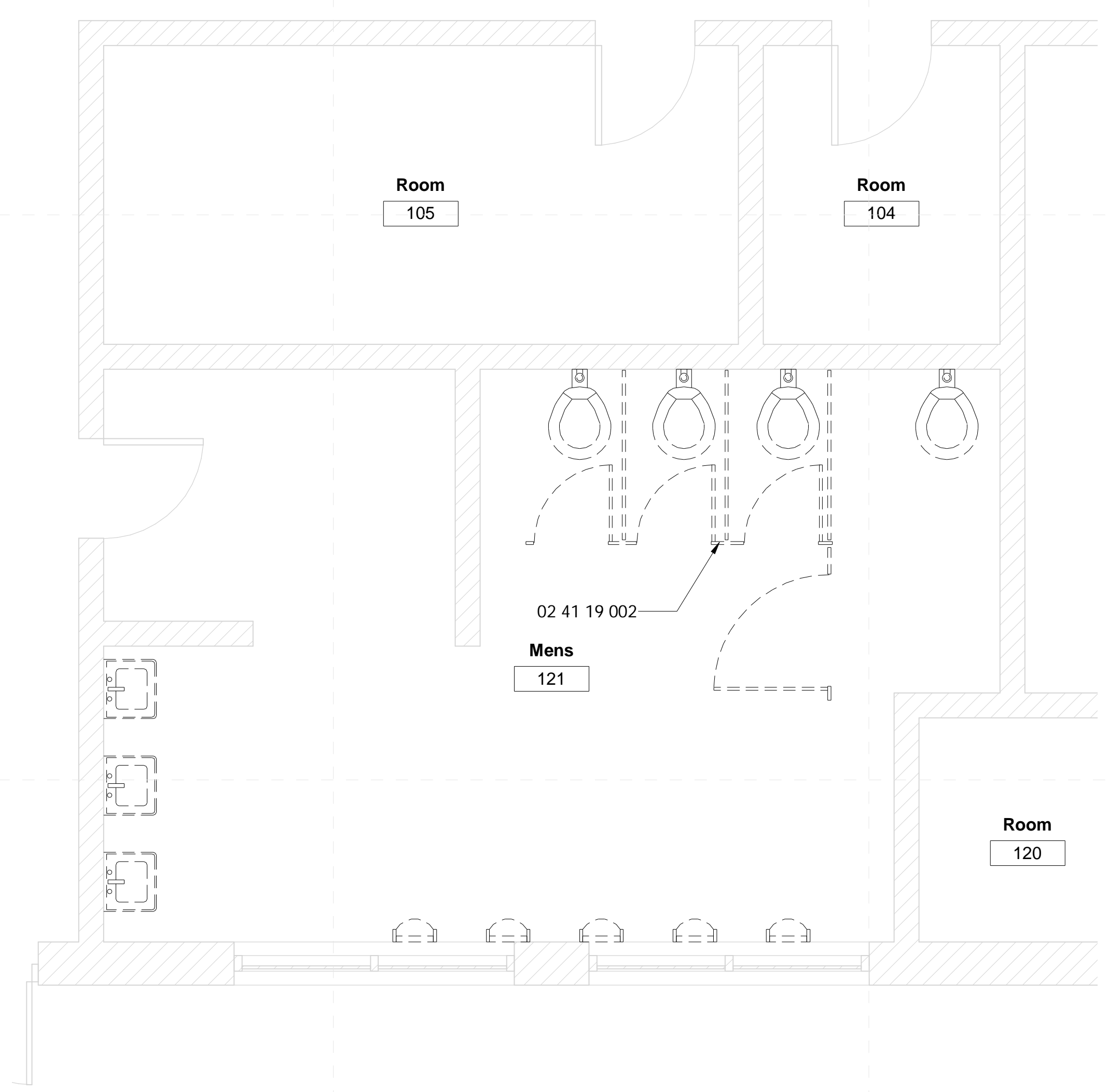
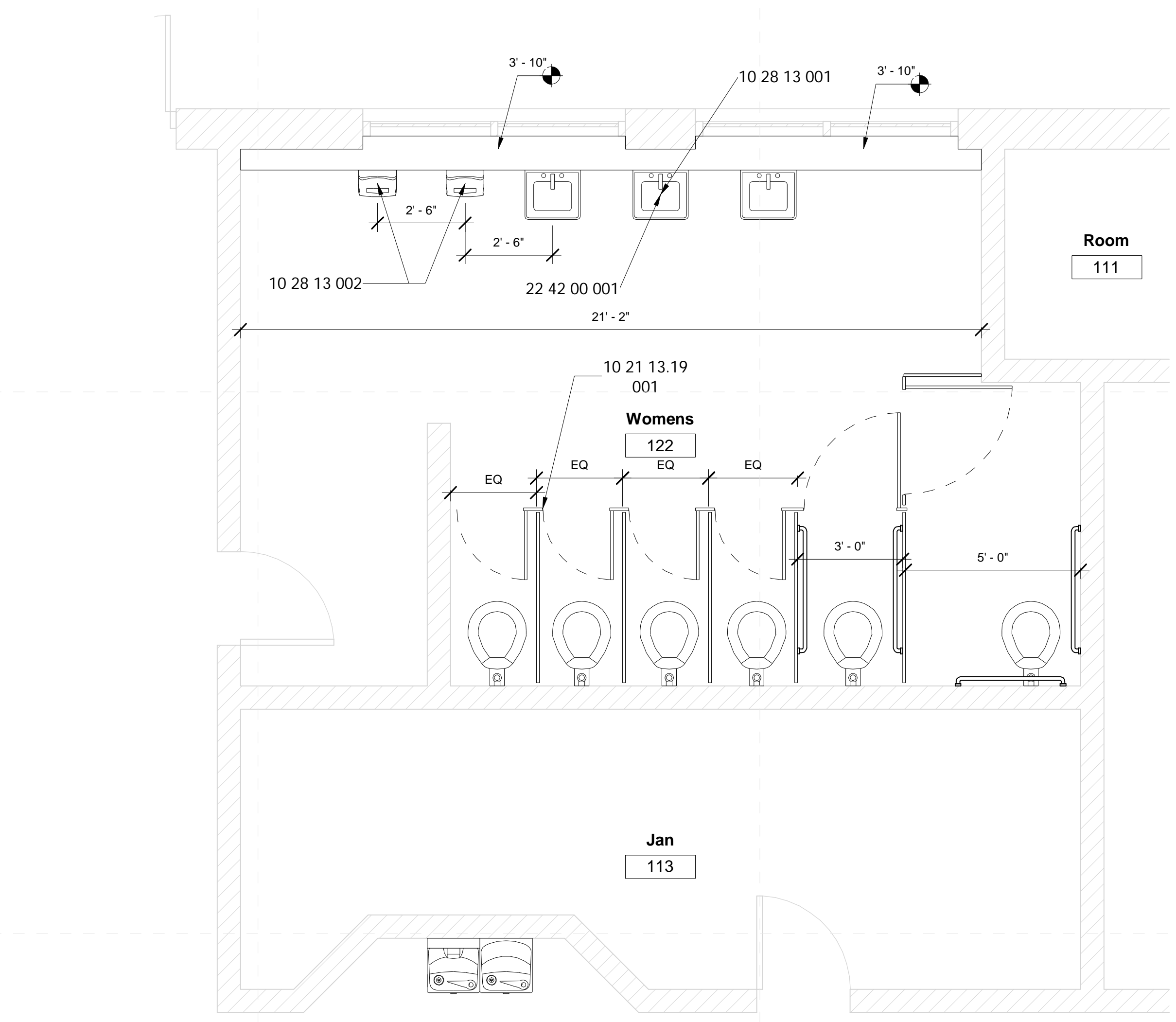
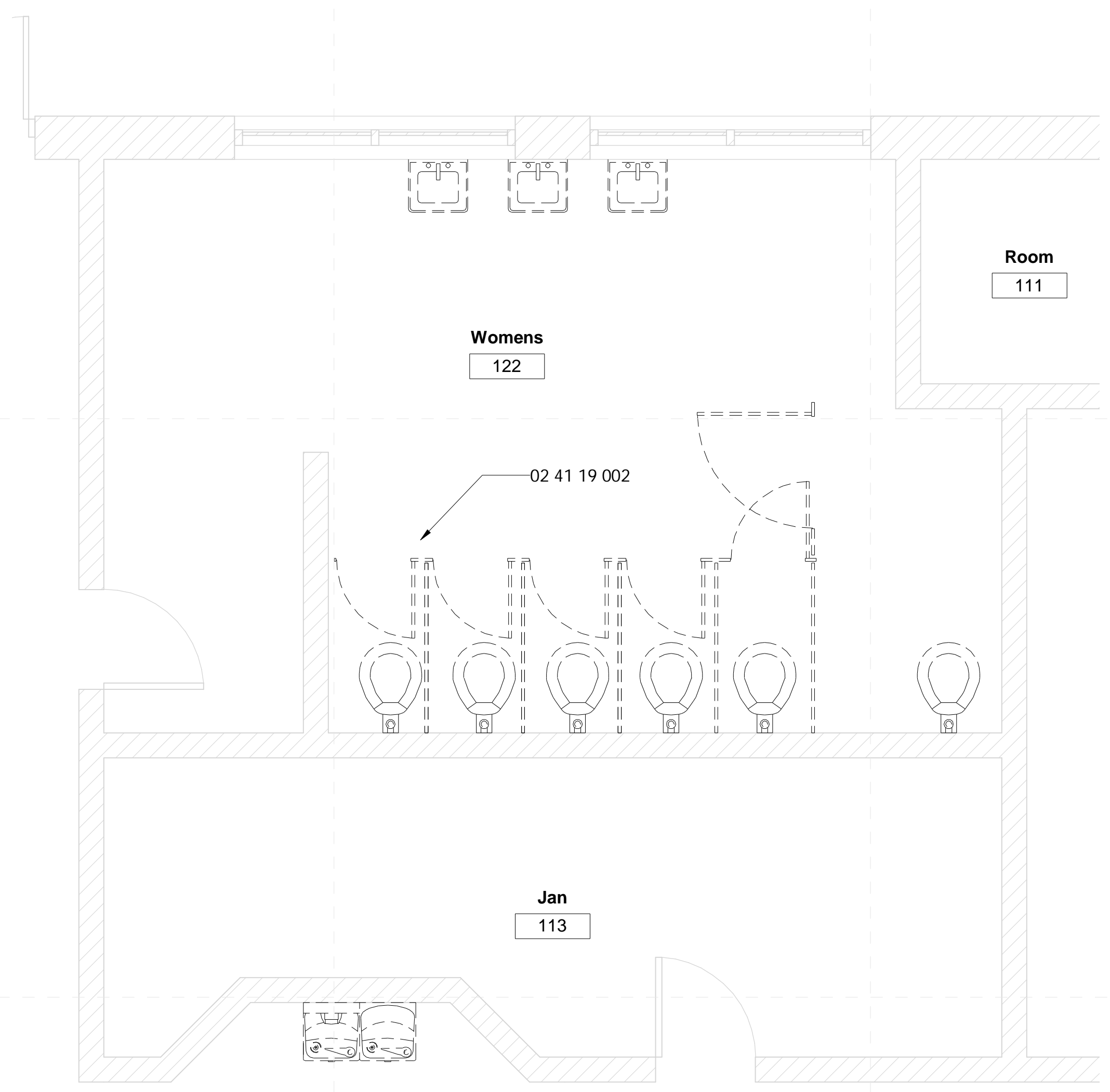

1 Toilets (Central) - Demolition  
3/8" = 1'-0"

2 Toilets (Central) - New Construction  
3/8" = 1'-0"

General Demolition Notes

- Where floor transitions from new floor to existing floor, a floor transition strip is to be provided. A knock-down frame is to be provided in place of the existing frame where the opening is a part of corridor.
- Remove all existing flooring, ceiling tile, rubber base, etc., where shown to be replaced by new materials in the finish schedule. RE: Floors plans, RCP, and Finish Schedule
- Owner has right of refusal for all demo work. If not retained, GC to be responsible for disposal.
- Verify all existing conditions. Notify architect of any discrepancies between the existing conditions and these documents. The Contractor is to consider the additional work required by any discrepancies to be included in this Contract.
- Burying or Burning of materials will not be permitted on site.
- Repair any damage caused to building construction identified to remain.
- Refer to other discipline drawings for additional demolition information as noted.
- Schedule with the Owner any demolition that involves exposing to the weather the interior portions of building to remain. This work is to be performed during good, dry weather or temporary waterproof barrier walls shall be constructed at all occurrences where the demolition exposes weather to the interior of portions of buildings to remain.
- Existing loose school property to be the responsibility of the school district, removal of property by owner to be coordinated between the contractor and school district.
- Where areas are removed or altered, patch, repair, & paint to match adjacent surface material and finish.

Specific Notes

02 41 19 002	Dashed lines indicated extent of demoed work
10 21 13.19 001	Install new toilet partitions (typical)
10 28 13 001	Install wall hung mirror here: center over fixture unless noted otherwise
10 28 13 002	Install hand dryer here: coordinate with electrical & mechanical
22 42 00 001	Coordinate new fixture installations with mechanical, typical for new

General Finish Plan Notes

- All flooring transitions are to occur at center line of door panel.
- Patch tile at all floors and walls with matching material where missing or removed due to construction, unless noted otherwise.
- New Fixture locations shall be coordinated with mechanical sheets.
- Install new grab bars at all ADA & AMB toilets
- Paint all exposed CMU at renovated toilets.
- Paint all tile wainscot.
- Clean floor grout and reseal.

**DALE BAILEY**  
AN ASSOCIATION

Architects

One Jackson Place 250  
188 East Capitol Street  
Jackson, MS 39201  
p 601.352.5411

201 Park Court Suite B  
Ridgeland, MS 39157  
p 601.790.9432

161 Lameuse St. Suite 201  
Biloxi, MS 39530  
p 228.374.1409

dalebaileyplans.com



Sunflower Consolidated School District ESSER 2&3 Phase I  
Lockard Elementary School: 302 College Ave., Indianola, MS 38751

Construction Documents

Project No	21027
Date	Issue Date
Revisions	Rev Date

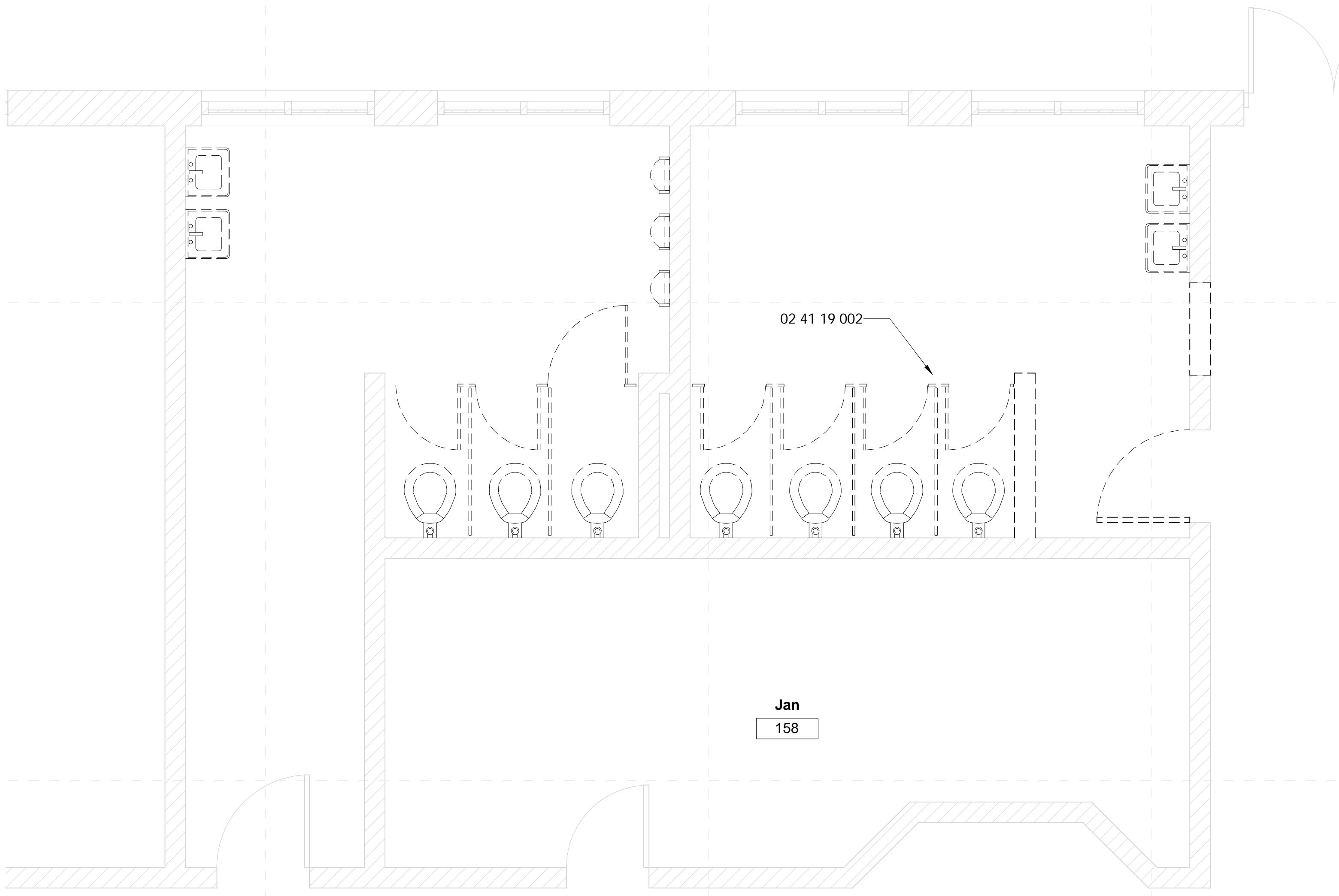

**1 Toilets (South) - Demolition**  
3/8" = 1'-0"

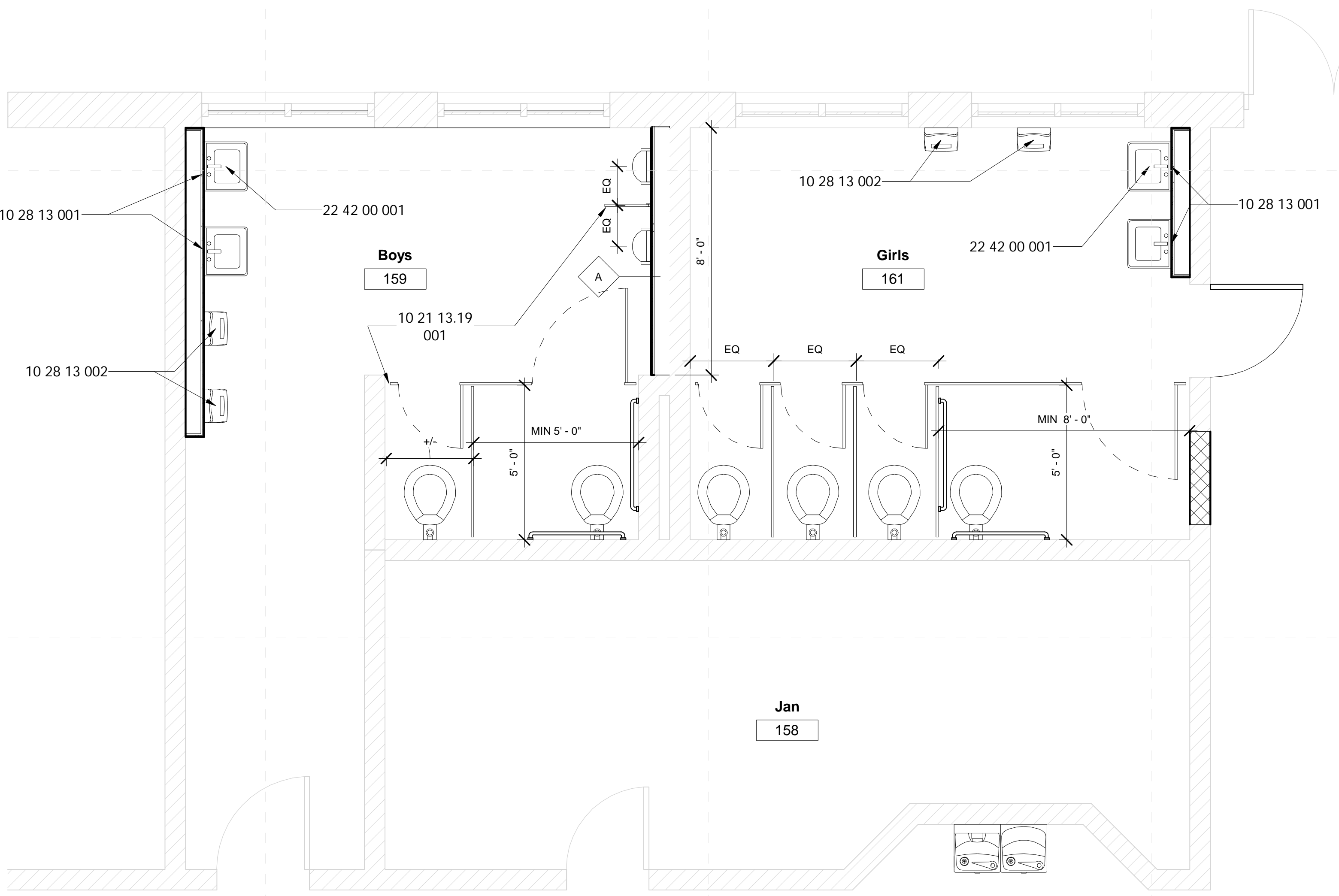

**2 Toilets (South) - New Construction**  
3/8" = 1'-0"

**General Demolition Notes**

- Where floor transitions from new floor to existing floor, a floor transition strip is to be provided. A knock-down frame is to be provided in place of the existing frame where the opening is a part of corridor.
- Remove all existing flooring, ceiling tile, rubber base, etc., where shown to be replaced by new materials in the finish schedule. RE: Floors plans, RCP, and Finish Schedule
- Owner has right of refusal for all demo work. If not retained, GC to be responsible for disposal.
- Verify all existing conditions. Notify architect of any discrepancies between the existing conditions and these documents. The Contractor is to consider the additional work required by any discrepancies to be included in this Contract.
- Burying or Burning of materials will not be permitted on site.
- Repair any damage caused to building construction identified to remain.
- Refer to other discipline drawings for additional demolition information as noted
- Schedule with the Owner any demolition that involves exposing to the weather the interior portions of building to remain. This work is to be performed during good, dry weather or temporary waterproof barrier walls shall be constructed at all occurrences where the demolition exposes weather to the interior of portions of buildings to remain.
- Existing loose school property to be the responsibility of the school district, removal of property by owner to be coordinated between the contractor and school district.
- Where areas are removed or altered, patch, repair, & paint to match adjacent surface material and finish.

**Specific Notes**

02 41 19 002	Dashed lines indicated extent of demolded work
10 21 13.19 001	Install new toilet partitions (typical)
10 28 13 001	Install wall hung mirror here: center over fixture unless noted otherwise
10 28 13 002	Install hand dryer here: coordinate with electrical & mechanical
22 42 00 001	Coordinate new fixture installations with mechanical, typical for new

**General Finish Plan Notes**

- All flooring transitions are to occur at center line of door panel.
- Patch tile at all floors and walls with matching material where missing or removed due to construction, unless noted otherwise.
- New Fixture locations shall be coordinated with mechanical sheets.
- Install new grab bars at all ADA & AMB toilets
- Paint all exposed CMU at renovated toilets.
- Paint all tile wainscot.
- Clean floor grout and reseal.

**DALE BAILEY**  
AN ASSOCIATION

Architects

One Jackson Place 250  
188 East Capitol Street  
Jackson, MS 39201  
p 601.352.5411

201 Park Court Suite B  
Ridgeland, MS 39157  
p 601.790.9432

161 Lameuse St. Suite 201  
Biloxi, MS 39530  
p 228.374.1409

dalebaileyplans.com

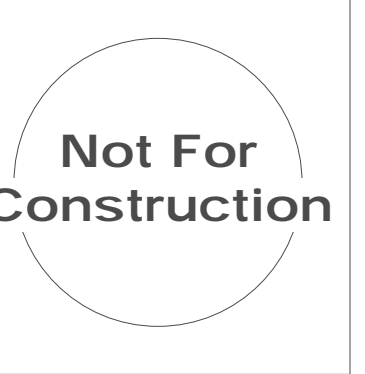

Sunflower Consolidated School District ESSER 2&3 Phase I  
Lockard Elementary School: 302 College Ave., Indianola, MS 38751

Construction Documents

Project No	21027
Date	Issue Date
Revisions	Rev Date

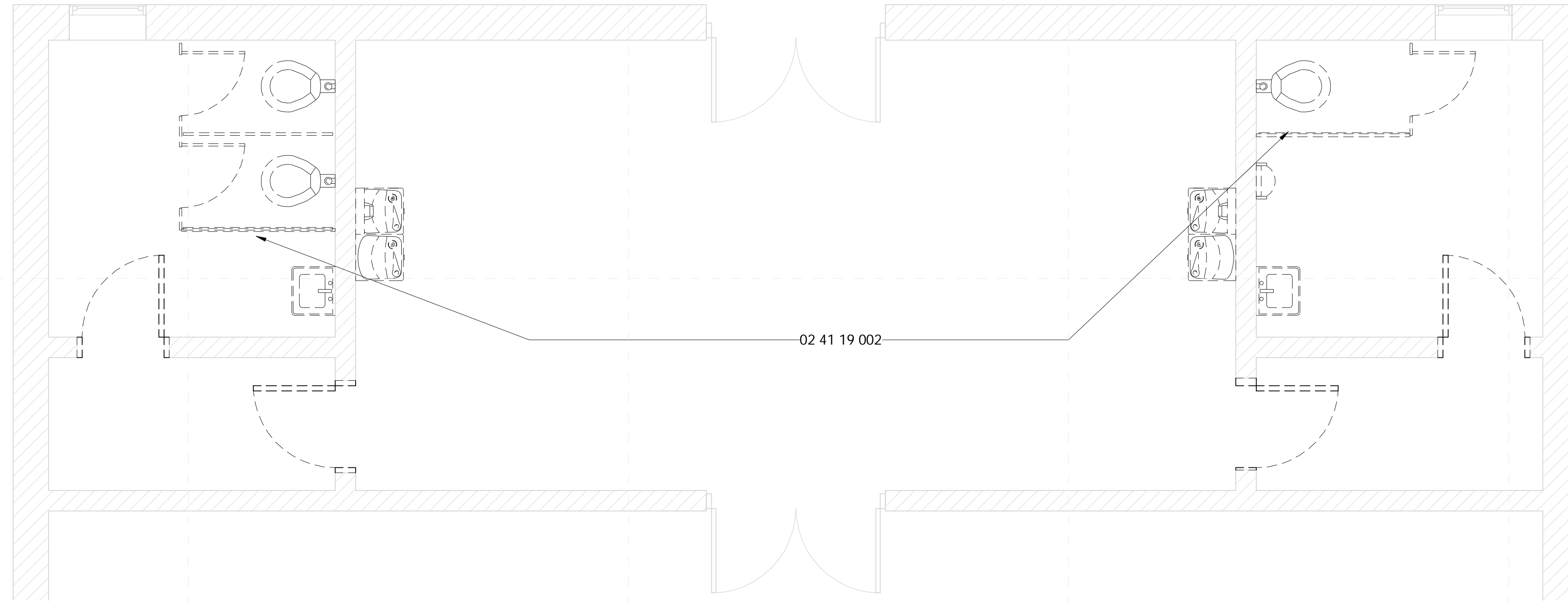

**1 Toilets (Auditorium) - Demolition**  
3/8" = 1'-0"

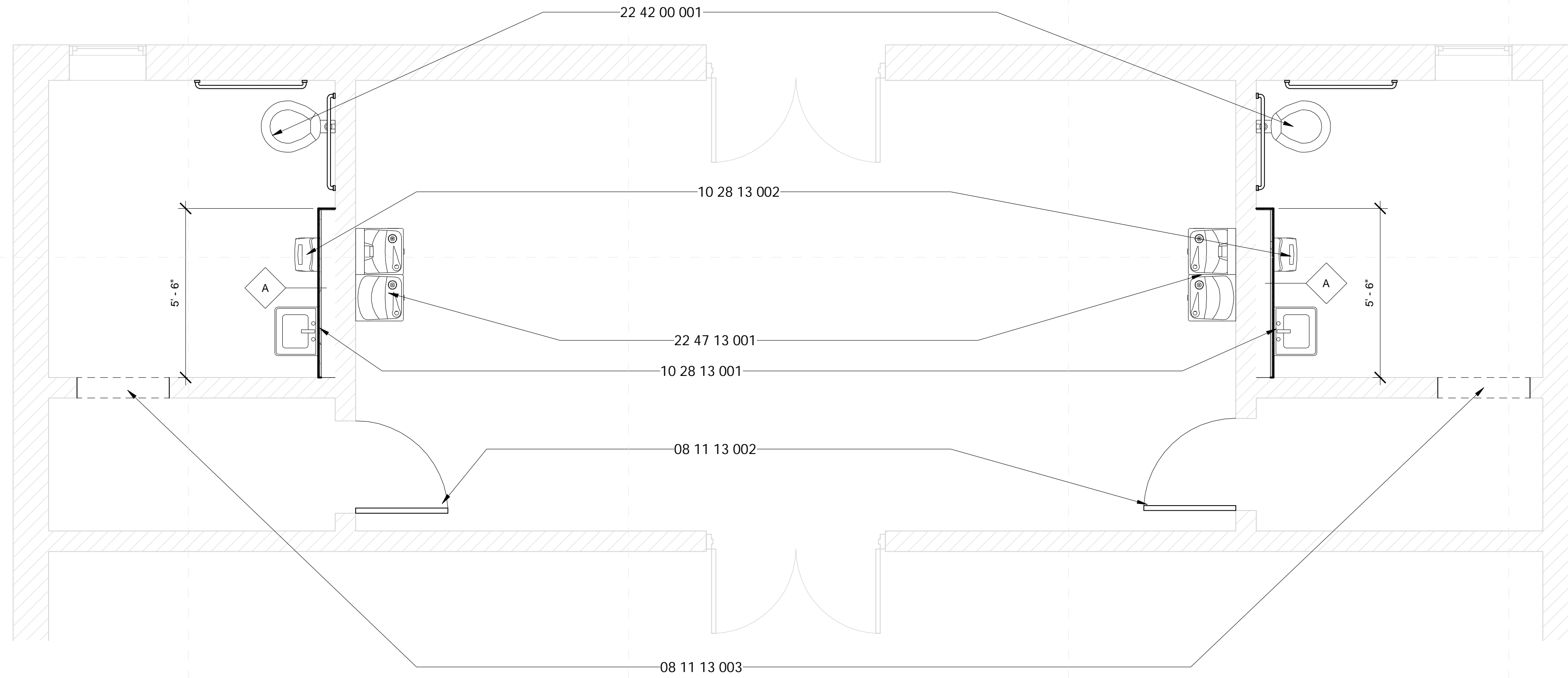

**2 Toilets (Auditorium) - New Construction**  
3/8" = 1'-0"

**General Demolition Notes**

- Where floor transitions from new floor to existing floor, a floor transition strip is to be provided. A knock-down frame is to be provided in place of the existing frame where the opening is a part of corridor.
- Remove all existing flooring, ceiling tile, rubber base, etc., where shown to be replaced by new materials in the finish schedule. RE: Floors plans, RCP, and Finish Schedule
- Owner has right of refusal for all demo work. If not retained, GC to be responsible for disposal.
- Verify all existing conditions. Notify architect of any discrepancies between the existing conditions and these documents. The Contractor is to consider the additional work required by any discrepancies to be included in this Contract.
- Burying or Burning of materials will not be permitted on site.
- Repair any damage caused to building construction identified to remain.
- Refer to other discipline drawings for additional demolition information as noted.
- Schedule with the Owner any demolition that involves exposing to the weather the interior portions of building to remain. This work is to be performed during good, dry weather or temporary waterproof barrier walls shall be constructed at all occurrences where the demolition exposes weather to the interior of portions of buildings to remain.
- Existing loose school property to be the responsibility of the school district, removal of property by owner to be coordinated between the contractor and school district. Where areas are removed or altered, patch, repair, & paint to match adjacent surface material and finish.

**Specific Notes**

02 41 19 002	Dashed lines indicated extent of demoed work
08 11 13 002	Install new 36" HM Door and Frame with new hardware
08 11 13 003	Remove Door jambs and finish masonry edge; ensure MIN 32" wide opening; paint to match CMU
10 28 13 001	Install wall hung mirror here; center over fixture unless noted otherwise
10 28 13 002	Install hand dryer here; coordinate with electrical & mechanical
22 42 00 001	Coordinate new fixture installations with mechanical, typical for new
22 47 13 001	Install double drinking fountain here; coordinate with mechanical & electrical drawings

**General Finish Plan Notes**

- All flooring transitions are to occur at center line of door panel.
- Patch tile at all floors and walls with matching material where missing or removed due to construction, unless noted otherwise.
- New Fixture locations shall be coordinated with mechanical sheets.
- Install new grab bars at all ADA & AMB toilets
- Paint all exposed CMU at renovated toilets.
- Paint all tile wainscot.
- Clean floor grout and reseal.

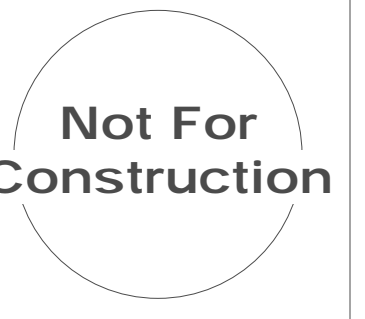

Project No	21027
Date	Issue Date
Revisions	Rev Date